

FLAME 49

Semi automatic
Flame treatment machine



DUBUIT
Screen Printing Machinery
www.dubuitfareast.com



The **Flame 49 machine** is designed to flame treat square, round and oval objects (4 sides in one single cycle). The machine starts rotating once the object is set on the tray. The rotation of the device also ignites the burner automatically.

The rotating system underneath the tray adapts its movements to maintain the burner constantly at the optimal distance from the object. For square objects, a sensor turns off the burner to avoid flaming the corners.

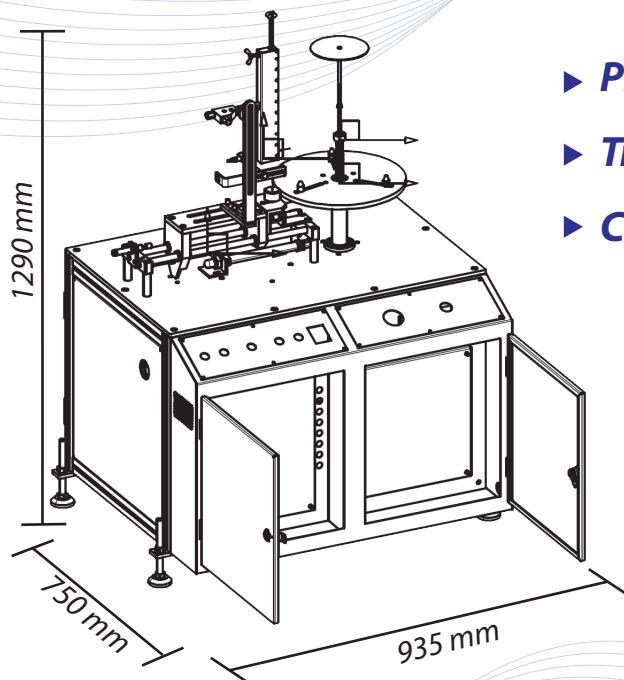

- ▶ **Practical use for crates, pails and oval objects**
- ▶ **Treats various sizes of objects**
- ▶ **Compact heavy duty machine, easy to maintain**



Samples cured by Flamer 49

SPECIFICATIONS

POWER	0.4 kW
SIZE OF OBJECTS	
Max. Height	350 mm
Min. Height	230 mm
PAIL & OVAL OBJECTS	
Diameter Max.	400 mm
Diameter Min.	140 mm
CRATE OBJECTS	
Diagonal distance Max.	600 mm
Diagonal distance Min.	400 mm
GAS CONSUMPTION	0.4-1 Nm ³ /h

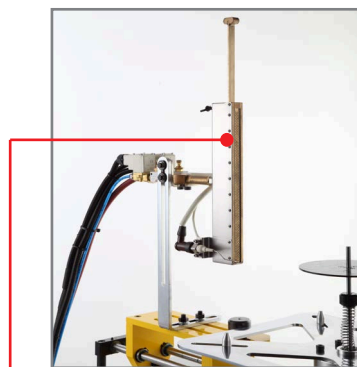

Flame sensor



Auto adjustable tray