

LEAK TESTER

740 mark II

For 0.5 to 5 liters containers

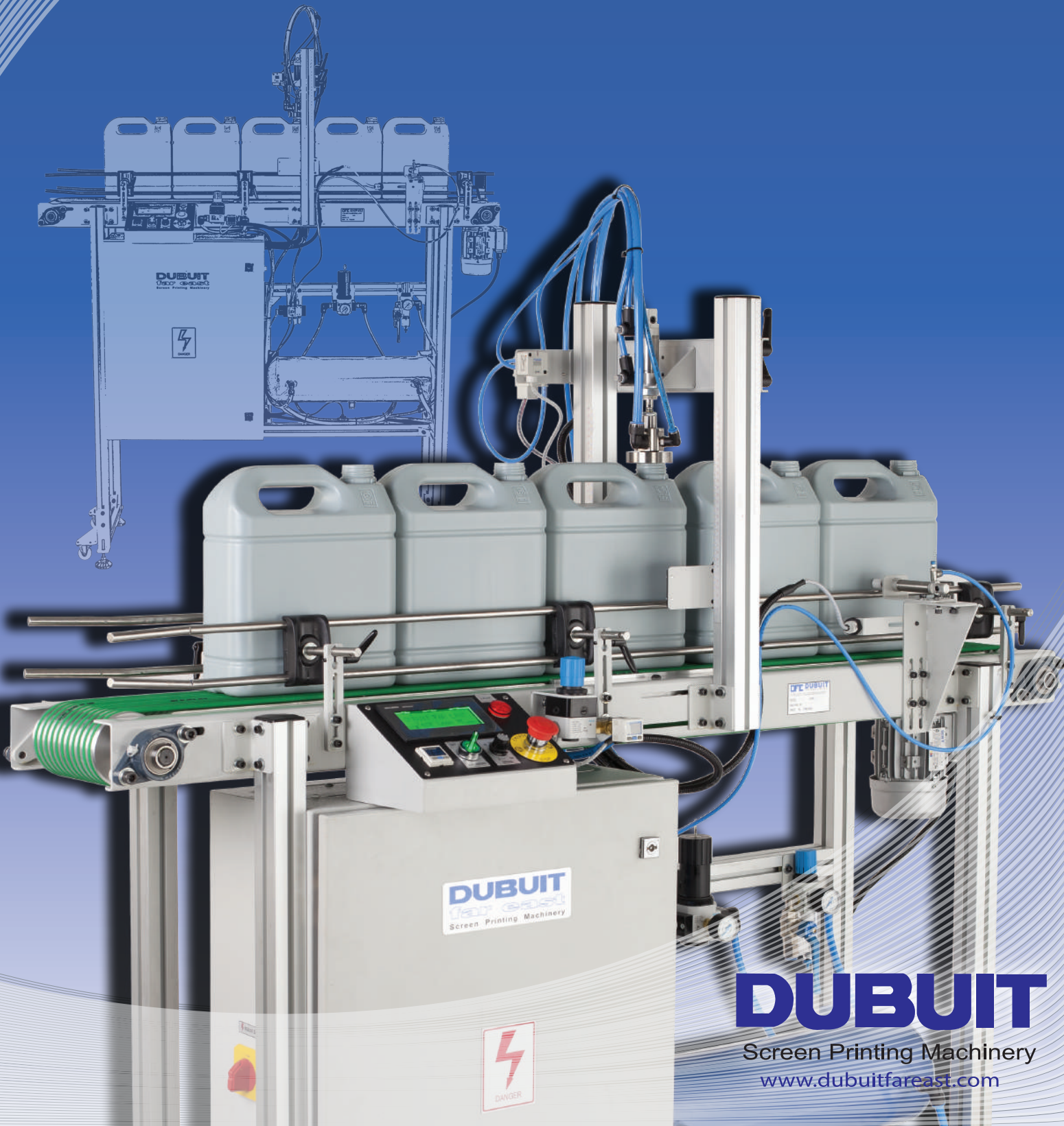

DUBUIT

Screen Printing Machinery
www.dubuitfareast.com

Leak tester 740



DUBUIT

The Leak Tester 740 has been specially designed to detect very small holes (down to 0.2 mm) on any shaped containers, such as bottles and jerry cans, without complex adjustment of the machine regarding the test (pressure or timing settings) at high speeds.

Possibly the most modern and easy to use leak tester in the market using pressure differential sensors. Featuring universal application with capability to test small containers from around 50ml up to Jerry cans of 5 liters and electronic testing circuit that is using presets so that no test parameters are needed to be changed from one container size to another.

Thanks to its unique testing method, it has a very short testing time which allows an output up to 2000 containers per hour. Its digital screen makes readouts for amount of tested and rejected bottles easier.

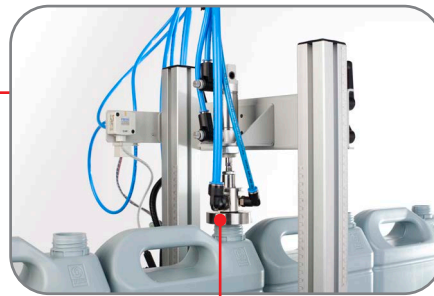
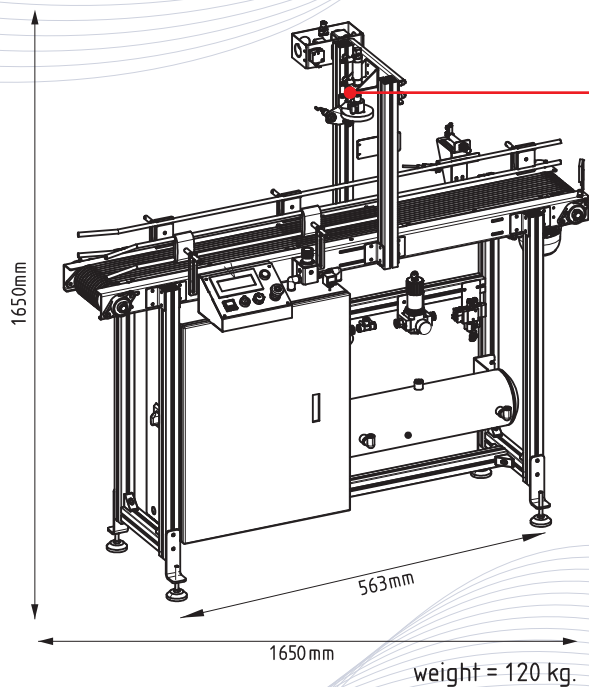

Automatic pressure filling cap

- ▶ **Easy to operate (various presets)**
- ▶ **Fully automatic**
- ▶ **Flexible machine**
- ▶ **High speed operation**

TECHNICAL DATA

OBJECTS DIMENSIONS

Height	Min	40 mm
	Max	320 mm
Diameter/width	Max	160 mm
	Diameter of neck	Min 20 mm Max 60 mm

TEST RATE (estimated)

0.5 liter	2200	containers/h
1 liter	2000	containers/h
2 liters	1100	containers/h
4 liters	1050	containers/h
5 liters	1000	containers/h

HEIGHT OF CONVEYOR

adjustable from 900 mm to 1060 mm

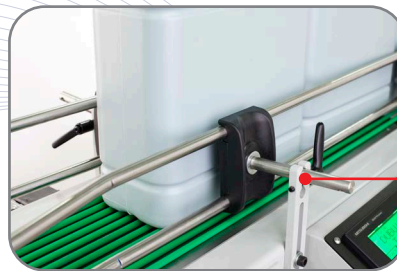

Adjustable conveyor size



Sensor control



Easy-to-use controls



Rejection device for leaking objects

DUBUIT

Screen Printing Machinery

www.dubuitfareast.com

NO. 11/34 Moo 6, Klong 3, Klong Luang,
PATHUMTHANI 12120 THAILAND
Tel: +66 (0) 25240929 Fax: +66 (0) 25240828
e-mail: export@dubuitfareast.com